

Analysis of the Motion Control Methods for Stratospheric Balloon-Borne Gondola Platform

H H Wang^{1,2}, Z H Yuan¹ and J Wu¹

¹ College of Automation, Northwestern Polytechnical University, Xi'an, China

² Northwestern Polytechnical University 182#, Xi'an, China, 710072

E-mail: wanghonghui@nwpu.edu.cn

Abstract. At present, gondola platform is one of the stratospheric balloon-borne platforms being in research focus at home and overseas. Comparing to other stratospheric balloon-borne platforms, such as airship platform, gondola platform has advantages of higher stability, rapid in motion regulation and lower energy cost but disadvantages of less supporting capacity and be incapable of fixation. While all platforms have the same goal of keeping them at accurate angle and right pose for the requirements of instruments and objects installed in the platforms, when platforms rotate round the ground level perpendicular. That is accomplishing motion control. But, platform control system has factors of low damper, excessive and uncertain disturbances by the reason of its being hung over balloon in the air, it is hard to achieve the desired control precision because platform is ease to deviate its benchmark motion. Thus, in the controlling procedure in order to get higher precision, it is crucial to perceive the platform's swing synchronously and rapidly, and restrain the influence of disturbances effectively, keep the platform's pose steadily. Furthermore, while the platform in the air regard control center in the ground as reference object, it is ultimate to select a appropriate reference frame and work out the coordinates and implement the adjustment by the PC104 controller. This paper introduces the methods of the motion control based on stratospheric balloon-borne gondola platform. Firstly, this paper compares the characteristic of the flywheel and CMG and specifies the key methods of obtaining two significant states which are 'orientation stability' state and 'orientation tracking' state for platform motion control procedure using CMG as the control actuator. These two states reduce the deviation amplitude of rotation and swing of gondola's motion relative to original motion due to stratospheric intense atmosphere disturbance. We define it as the first procedure. In next procedure, we use the transfer matrix of earth reference frame to geographic reference frame to transform the data measured by the magnetic orientation sensors and the gyroscope to the space orientations, then the PC104 controller use the space orientations value as feedback to complete revises.

1. Introduction

It is a primary approach to perform researches in some scientific fields, such as astronomy, high-energy physics, aerology, remote sensing engineering, bioengineering etc, that keeping the balloon which suspends a definite mass and volume cockpit under it with special rope extend from 10 meters to 100meters long float in the stratosphere. While some equipment and instruments are installed in the cockpit to gather needed information. We call this suspended cockpit as "balloon-borne platform" or "stratospheric balloon-borne platform".

At present, gondola platform is one of the stratospheric balloon-borne platforms being in research focus. Comparing to other stratospheric balloon-borne platforms, such as airship platform, gondola

platform has advantages of higher stability, rapid in motion regulation and lower energy cost but disadvantages of less supporting capacity and be incapable of fixation in the air.

But, when gondola platform as well as other balloon-borne platform floats in the stratosphere, it is easy to deviate its benchmark pose because of uncertain external disturbances and its own factors of low damper. Thereby, the instruments and objects in the platform can't gather data and information effectively and normally for they are not at desired orientation. Generally speaking, the platform's motion can be defined two types, basically: rotation round the ground level perpendicular and wiggle relative to the ground level perpendicular. This two motion modes determine the platform's orientation or deviation relative to its so-called benchmark pose. So the motion control system of gondola platform plays a key role in the system, it has two tasks of keeping platform's motion in a steady state and tracking the desired orientation rapidly, we call them as 'orientation stability' and 'orientation tracking' state or procedure.

In addition, if platform's benchmark pose make reference to ground objects, we must select geographic reference frame as coordinate system. While the data measured by the magnetic orientation sensors and the gyroscope use earth reference frame as reference frame, so we still must transform the data relative to earth reference frame to the data relative to geographic reference frame.

This paper introduces control methods that how to implement the two procedures and transform matrix from earth reference frame to geographic reference frame, then PC104 controller complete the error correction.

2. How to keep platform in desired pose?

As is well known, if you want to change one object's pose, you must apply a given torsion or force on it. It is very easy to achieve on ground because the ground (the earth) can give you counterforce, but in the air it is comparatively difficult. Unfortunately, the balloon in the air and the gondola suspended under balloon are in the situation. We can give them torsions that will change their poses or motions, but who can give them the counterforce? Now, we begin to go about it.

2.1. Inertia Working Principle

We can make use of inertia working principle to bring the counterforce for the torsion which is applied to change one platform's pose. We can use selectively flywheel or Control Moment Gyro(CMG) as actuators. Now, we will specify their working principle and compare their characteristics. Figure1 is control system work principle figure based on flywheel, Figure2 is control system work principle figure based on CMG.

As figure1 shows, a flywheel is mounted on the axes of DC servo moment motor through flywheel's center of gravity. When system begins work, motor drives flywheel rotate at a quite low and stable speed ω_0 , this is initial state. When motor accelerates or decelerates, the acceleration can be noted as $d\omega/dt$, then there will bring moment for the reason of flywheel's inertial. The reactive torsion is:

$$T = J \cdot d\omega/dt \quad (1)$$

J is flywheel's inertia coefficient and T 's direction is decided by $d\omega/dt$'s sign. So we can use this torsion produced by flywheel's inertia to counteract the torsion due to external disturbance. This method has a very simple structure, but has disadvantages of ponderosity and motor's rotate speed being saturated easily.

So we select CMG as the actuator, CMG also works according to inertia principle and also produces the reaction torsion by changing the correction motor's rotate speed. But it has more advantages. Table1 gives the comparison between them.

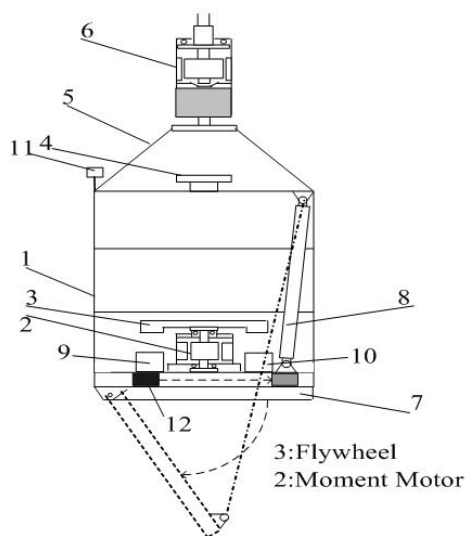

Figure 1. Control system work principle figure based on flywheel.

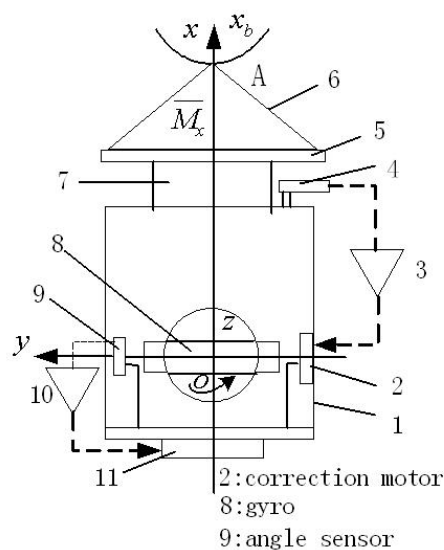

Figure 2. Control system work principle figure based on CMG.

Table 1. Characteristics comparison between flywheel and CMG.

	Weight	Stable Torsion	Stability	Precision	Structure	Cost
Flywheel	heavy	saturate easily	bad	low	simple	low
CMG	light	saturate uneasily	good	high	complex	high

2.2. Orientation Stability

It is proved by ample experimentation data that platform's rotation is more intense than its wiggle or swing, so we consider the rotation firstly. We can define three parameters: azimuth θ_a , roll angle θ_r , and pitching angle θ_p , only azimuth θ_a is effected by the rotation, others lie on the wiggle. The goal of 'orientation stability' is to deduce influence of the external disturbance for the controller's adjustment of next step and keep platform more stable, then it is convenient for the controller to keep azimuth θ_a consistent with the given θ'_a . But, the disturbance also leads to the balloon's rotation which will make rope screw tighter and tighter and then produce redundant torsion. When this redundant torsion is bigger than maximum output torsion produced by CMG's inertial, CMG will lose the capacity of reactive torsion for its inertial torsion must counteract redundant torsion firstly. So we design a decoupling machine to deduce the influence of the balloon's rotation. Figure3 shows the structure of decoupling machine.

Decoupling machine includes 3 parts: bearing, motor and deceleration gear. Bearing's function is to sustain the transmission part and reduce the friction. Motor is decoupling actuator, it is controlled by controller when controller detects that there is torsion in the rope. For example, showed by figure3, suspended rope is fixed on the motor's shaft, if rope is screwed at counter-clockwise, controller must detect the torsion at clockwise via torque sensor, so controller drives motor rotate at clockwise until torsion goes to zero. Deceleration gear can deduce the modulation speed and absorb the shock for changes of speed. So decoupling machine deduces the influence of the balloon's rotation, furthermore, we use CMG's correction motor to correct the error between azimuth θ_a and given θ'_a , the gondola must be in stable state, the procedure of correction can be seen in 'orientation tracking'.

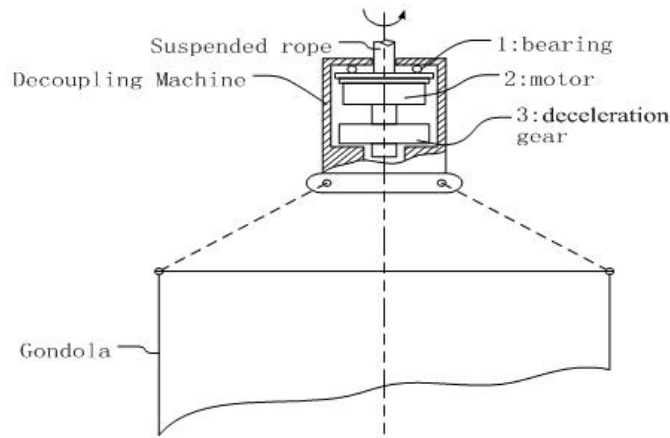

Figure 3. The structure of decoupling machine.

2.3. Orientation Tracking

In a general way, platform only keeps motion stability momentarily because disturbance acts on platform continually, on the side, the given θ'_a may be changed for instruments' need. So we must adjust gondola's motion and azimuth θ_a constantly, that is 'orientation tracking'. On the side, roll angle θ_r and pitching angle θ_p also influence the orientation of instruments in platform and azimuth θ_a , so the task of 'orientation tracking' is to correct the error between azimuth θ_a and the given θ'_a according to the relationship among $\theta_a, \theta_r, \theta_p$. The procedure of correction sees figure4.

The magnetic orientation sensor is mounted on the platform flatly, its direction of pointing North Pole is fixed. Sees figure4, in A state, platform is stable. If θ'_a has changed or $\theta_a, \theta_r, \theta_p$ have changed for external disturbance, platform is in B state, the magnetic orientation sensors can measure this $\Delta\theta_a$ offset. Then controller uses the error as the control variable and makes correction motor accelerate or decelerate, inertial torsion makes platform rotate until $\Delta\theta_a \approx 0$, in C state, this is the procedure of orientation tracking. The relationship of $\theta_a, \theta_r, \theta_p$ can be seen in '3. Instruments' motion control'.

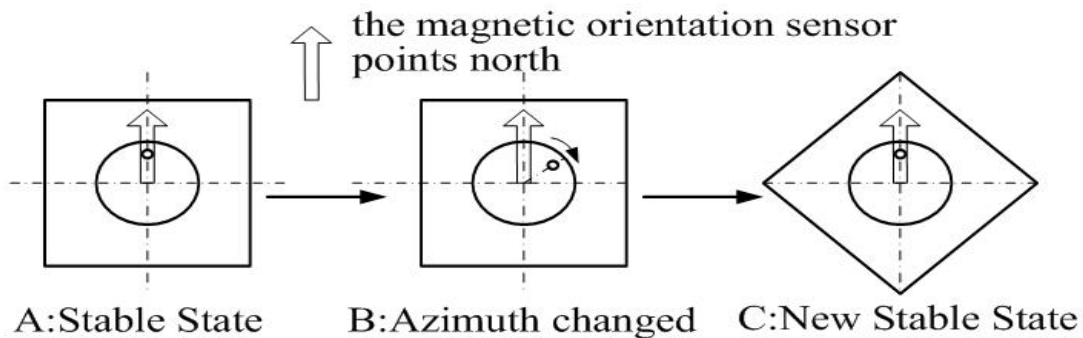

Figure 4. The procedure of orientation tracking.

3. Instruments' motion control.

In 'orientation stability' and 'orientation tracking' state, we keep platform in a relatively stable state and fixed pose. But this is not end, we need to control any one instrument move or rotate to specific motion. For example, we have an observation scope in platform, it can move at two degrees of freedom. When we want to change observe point, controller must modulate the motion of observation scope according to control center's instruction. While the data measured by the magnetic orientation sensors and the gyroscope uses earth reference frame as reference frame, so we still must transform the data relative to earth reference frame to the data relative to geographic reference frame.

Firstly, we should define the observation scope's own azimuth α^M and pitching angle β^M , these two angle can decide the observation scope's point direction. The control given variables are sent by ground control center, we define them as α^S and β^S . Figure5 shows the control block diagram.

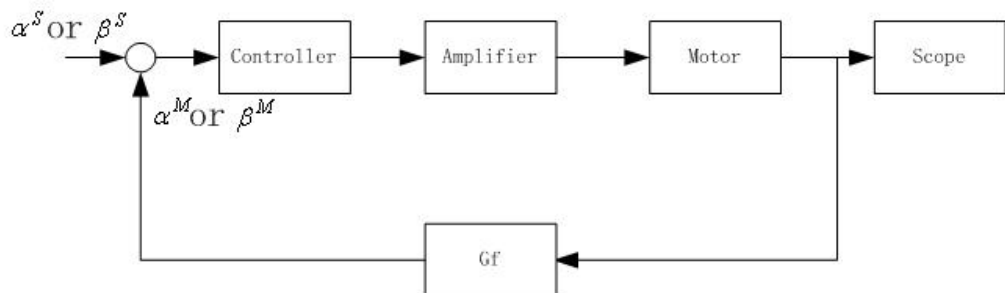

Figure 5. Observation scope's control block diagram.

3.1. Confirming α^S and β^S

We can confirm α^S and β^S refer to figure6, P_1 and P_2 are separately denoted platform and ground control center. While P_1 and P_2 's coordinates in earth reference frame can be written as:

$$P_i^E = \begin{bmatrix} (R+h) \cos \varphi \cdot \cos \lambda \\ (R+h) \cos \varphi \cdot \sin \lambda \\ ((1-e^2)R+h) \sin \varphi \end{bmatrix} \tag{2}$$

λ, φ, h denote longitude, latitude, altitude separately, they can be measured by GPS. Thereinto, $R = Re(1 - e^2 \sin^2 \varphi)^{-1/2}$, $Re = 6378137 \pm 2m$ as earth radius in equator, $e^2 = 0.00669437999013$ as earth ellipticity.

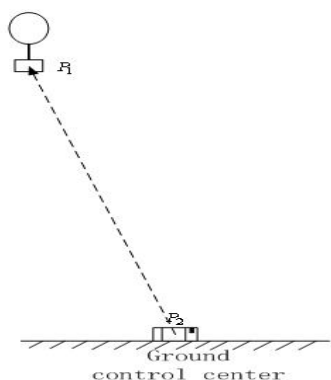

Figure 6. Position relationship between platform and ground control center.

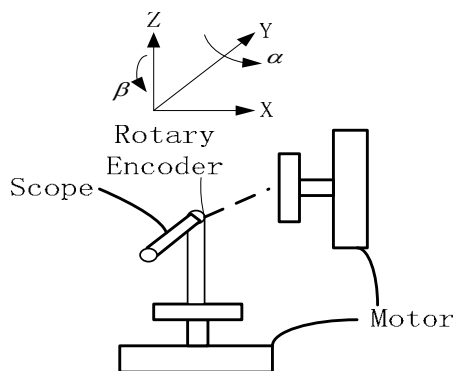

Figure 7. Scope's two degrees of freedom, α is azimuth, β is pitching.

Then how to transform P_1 and P_2 's coordinates from earth reference frame to geographic reference frame? We can use this equation:

$$\vec{y}^G = C_E^G (P_2^E - P_1^E) \tag{3}$$

C_E^G is transfer matrix, written as:

$$C_E^G = \begin{bmatrix} -90^\circ - \varphi \end{bmatrix}_y [\lambda]_z = \begin{bmatrix} -\sin \varphi & 0 & \cos \varphi \\ 0 & 1 & 0 \\ -\cos \varphi & 0 & -\sin \varphi \end{bmatrix} \begin{bmatrix} \cos \lambda & \sin \lambda & 0 \\ -\sin \lambda & \cos \lambda & 0 \\ 0 & 0 & 1 \end{bmatrix} \tag{4}$$

We can get according to (2),(3),(4):

$$\bar{\gamma}^G = \begin{bmatrix} x \\ y \\ z \end{bmatrix}^G = C_E^G \left((R_2 + h_2) \begin{bmatrix} \cos \varphi_2 \cdot \cos \lambda_2 \\ \cos \varphi_2 \cdot \sin \lambda_2 \\ \sin \varphi_2 \end{bmatrix} - \begin{bmatrix} 0 \\ 0 \\ e^2 R_2 \sin \varphi_0 \end{bmatrix} \right) + e^2 R \begin{bmatrix} \sin \varphi_1 \cdot \cos \varphi_1 \\ 0 \\ -\sin^2 \varphi_1 \end{bmatrix} - \begin{bmatrix} 0 \\ 0 \\ R + h \end{bmatrix} \quad (5)$$

This is the P_1 and P_2 's coordinates in geographic reference frame .Then:

$$\alpha^S = \arctan y^G \cdot (x^G)^{-1} \quad (6)$$

$$\beta^S = -\arctan z^G \cdot ((x^G)^2 + (y^G)^2)^{-1/2} \quad (7)$$

3.2. Calculating α^M and β^M

Now we need to calculate α^M and β^M via $\theta_a, \theta_r, \theta_p$ measured by sensors. Azimuth θ_a , is effected by the rotation, θ_r and θ_p lie on the wiggle. The any changes of θ_a, θ_r and θ_p will influence α^M and β^M . θ_a can be measured by the magnetic sensor , θ_r and θ_p can be measured by gyro, in addition, the rotary encoder of scope measures the pitch angle of itself, noted as β^R . So we can get:

$$\alpha' \cong \theta_a - \arctan(\theta_r \tan \beta^R) \quad (8)$$

This equation ignores the very small θ_p .

$$\beta' \cong \beta^R - \theta_r + 90^\circ \quad (9)$$

β' means the pitch angle relative to the horizontal level of earth.

Once again, we use equation (3) and get:

$$\alpha^M = C_E^G \alpha' \quad (10)$$

$$\beta^M = C_E^G \beta' \quad (11)$$

Finally, we have $\alpha^S, \beta^S, \alpha^M$ and β^M , PC104 controller can execute the control procedure in figure5. The control effect and precision is very good proved by the practical experimentation, the ignorance and predigest of the equation (8), (9) is feasible.

References

- [1] Okamura Yoshihiko and Imai Hiroko 2005 *Proceedings of SPIE - The International Society for Optical Engineering, Sensors, Systems, and Next-Generation Satellites IX*, **5978** pp 65-73
- [2] Huguenin Daniel 1994 *Infrared Physics & Technology, Topical Conference on Infrared Astrophysics* **35** pp 195-202
- [3] Ouyang Jin and Qu Weidong 2003 *Shanghai Jiaotong Daxue Xuebao/Journal of Shanghai Jiaotong University* **37** pp 956-960